



# SUBMITTAL DATA - **OUTDOOR UNIT**

## **VPA216L4M-2G**

### **VPA096L4M-2G + VPA120L4M-2G**

#### **VRF LOW AMBIENT HEAT PUMP**

**Job:** \_\_\_\_\_

**Location:** \_\_\_\_\_

**Schedule No.:** \_\_\_\_\_

**System Designation:** \_\_\_\_\_

**Engineer:** \_\_\_\_\_

**Architect:** \_\_\_\_\_

**Date:** \_\_\_\_\_

For: Reference Approval Review Construction

### FEATURES

- Built-in Base Pan Heater
- Hinged electrical box for ease of maintenance
- High efficiency DC Inverter scroll compressor
- Two-pipe heat pump

### SPECIFICATIONS

#### PERFORMANCE

Cooling Capacity <sup>1</sup> (Btu/h)	Nominal	216,000
	Rated <sup>2</sup>	206,000
EER	Ducted	10.60
	Non-Ducted	11.20
IEER	Ducted	20.20
	Non-Ducted	20.20
Heating Capacity <sup>1</sup> (Btu/h)		224,000
COP47	Ducted	3.45
	Non-Ducted	3.58
COP17	Ducted	2.23
	Non-Ducted	2.28

#### ELECTRICAL DATA

Power Supply <sup>3</sup> (V/Hz/Ph)	460/60/3
Minimum Circuit Ampacity (A)	32.1 + 34.4
Maximum Overcurrent Protection (A)	40 + 45
Compressor RLA (A)	12/11 + 13/12
No. of Compressors	2 + 2
Outdoor Fan Power Input (W)	(2) 750/750
Outdoor Fan FLA (A)	(2) 1.8/1.8

#### GENERAL DATA

Connection Ratio	50% to 130%
Max # of Indoor Units	36 units
Refrigerant type	R-410A
Factory refrigerant charge	22 lbs.

#### DIMENSIONS

Unit Dimensions (in.)	Height	63-1/8
	Width	49-1/4
	Depth	30-1/8
Liquid Pipe Connection (in.)		1/2
Gas Pipe Connection (in.)		7/8
Net Weight (lb)		(2) 781



### WARRANTY<sup>4</sup>

- Compressor - 10 year limited warranty
- All other components - 10 year limited warranty

### NOTES

1. Cooling and Heating Capacity data is rated at the following conditions:  
Cooling: 80°FDB / 67°FWB Indoor, 95°FDB Outdoor  
Heating: 70°FDB Indoor, 47°FDB / 43°FWB Indoor
2. Complies with AHRI 1230-2014 testing standards
3. Operating Voltage Range: 423V to 497V
4. See Warranty for Details





# SUBMITTAL DATA - **OUTDOOR UNIT**

## **VPA216L4M-2G**

## **VPA096L4M-2G + VPA120L4M-2G**

## **VRF LOW AMBIENT HEAT PUMP**

### DIMENSIONS - INCHES (MM)

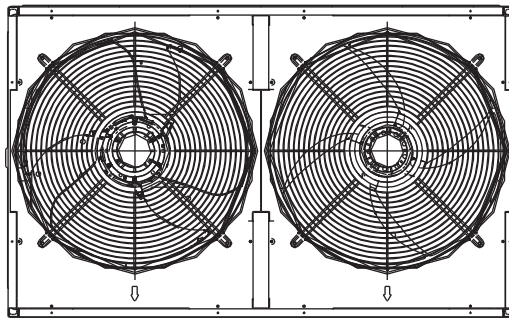

**TOP VIEW**

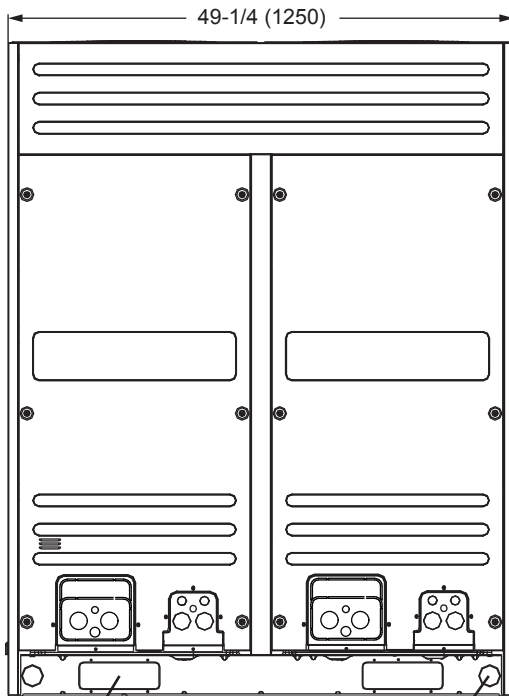

FORKLIFT SLOT  
(BOTH SIDES)

LIFTING HOLES  
(FOR RIGGING)

**FRONT VIEW**

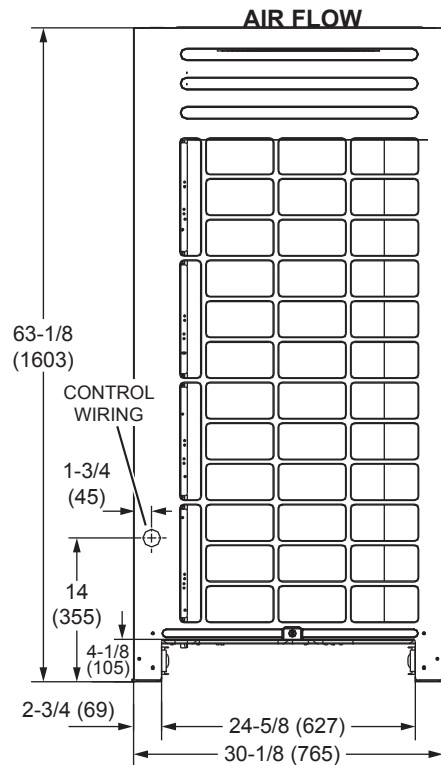

**AIR FLOW**



**AIR FLOW**

**SIDE VIEW**

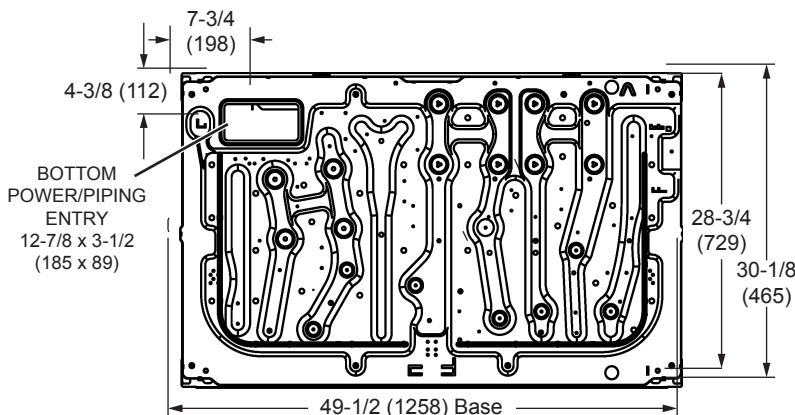

BOTTOM  
POWER/PIPING  
ENTRY  
12-7/8 x 3-1/2  
(185 x 89)

**BASE VIEW**

DISCLAIMER – Due to Lennox' ongoing commitment to quality, Specifications, Ratings and Dimensions subject to change without notice and without incurring liability. Improper installation, adjustment, alteration, service or maintenance can cause property damage or personal injury. Installation and service must be performed by a qualified installer and servicing agency.