



©2018 Lennox Industries Inc.  
Dallas, Texas, USA



**THIS MANUAL MUST BE LEFT WITH THE OWNER FOR FUTURE REFERENCE**

These instructions are intended as a general guide and do not supersede local codes in any way. Consult authorities having jurisdiction before installation.

**⚠ WARNING**

**Improper installation, adjustment, alteration, service or maintenance can cause property damage, personal injury or loss of life.**

**Installation and service must be performed by a licensed professional HVAC installer, service agency or the gas supplier.**

**Failure to follow safety warnings and these instructions exactly could result in property damage, dangerous operation, serious injury, or death.**

**Any additions, changes, or conversions required in order for the appliance to satisfactorily meet the application needs must be made by a licensed professional HVAC installer (or equivalent) using factory-specified parts.**

**Do not use this system if any part has been under water. A flood-damaged appliance is extremely dangerous. Immediately call a licensed professional HVAC service technician (or equivalent) to inspect the system and to replace all controls and electrical parts that have been wet, or to replace the system, if deemed necessary.**

**⚠ CAUTION**

As with any mechanical equipment, contact with sharp sheet metal edges can result in personal injury. Take care while handling this equipment and wear gloves and protective clothing.

To ensure proper system performance and reliability, Lennox does not recommend operation of VRF systems during any phase of construction. Construction debris, low temperatures, harmful vapors, and operation of the unit with misplaced filters can damage the units. Failure to follow these guidelines will result in the warranty being voided.

# INSTALLATION INSTRUCTION

## VWMB Wall-Mounted Units

VRF SYSTEMS -- Indoor Units  
507799-02  
05/2018

**⚠ IMPORTANT**

The Clean Air Act of 1990 bans the intentional venting of refrigerant (CFC's and HCFC's) as of July 1, 1992. Approved methods of recovery, recycling or reclaiming must be followed. Fines and/or incarceration may be levied for non-compliance.

**General**

The VWMB wall-mounted indoor units are matched with an outdoor heat recovery or heat pump unit to create a VRF (variable refrigerant flow) system that uses HFC-410A refrigerant. VWMB indoor units are designed for indoor installation only.

Refer to the Product Specification bulletin (EHB) for the proper use of these indoor units with specific heat pumps, heat recovery units, mode switching devices, branch pipes, line sets and controls.

These instructions are intended as a general guide and do not supersede local or national codes in any way.

Authorities having jurisdiction should be consulted before installation.

**Shipping and Packing List**

Check the components for shipping damage. If you find any damage, immediately contact the last carrier.

Package 1 of 2 contains the following:

- 1 - Assembled indoor unit with mounting bracket
- 8 - Mounting bracket securing screws
- 8 - Plastic screw anchors
- 1 - Roll tape
- 1 - Flexible condensate drain pipe
- 1 - Wall sleeve
- 1 - Plastic cover for wall sleeve
- 1 - Resistor
- 1 - Brass flare nut
- 1 - Water level switch cable
- 1 - Installation manual

## Safety Requirements

### ⚠ WARNING

#### ELECTRICAL SHOCK, FIRE, OR EXPLOSION HAZARD.

Do not touch the unit or the controller if your hands are wet.

DO NOT spray water on the indoor unit for any reason.

Do not replace a fuse with a fuse of a different rating. Do not use a jumper wire to replace a fuse. Do not insert your hands, tools or any other item into the air intake or air outlet at either the indoor or outdoor unit.

Do not allow children to operate the system.

## Model Number Identification

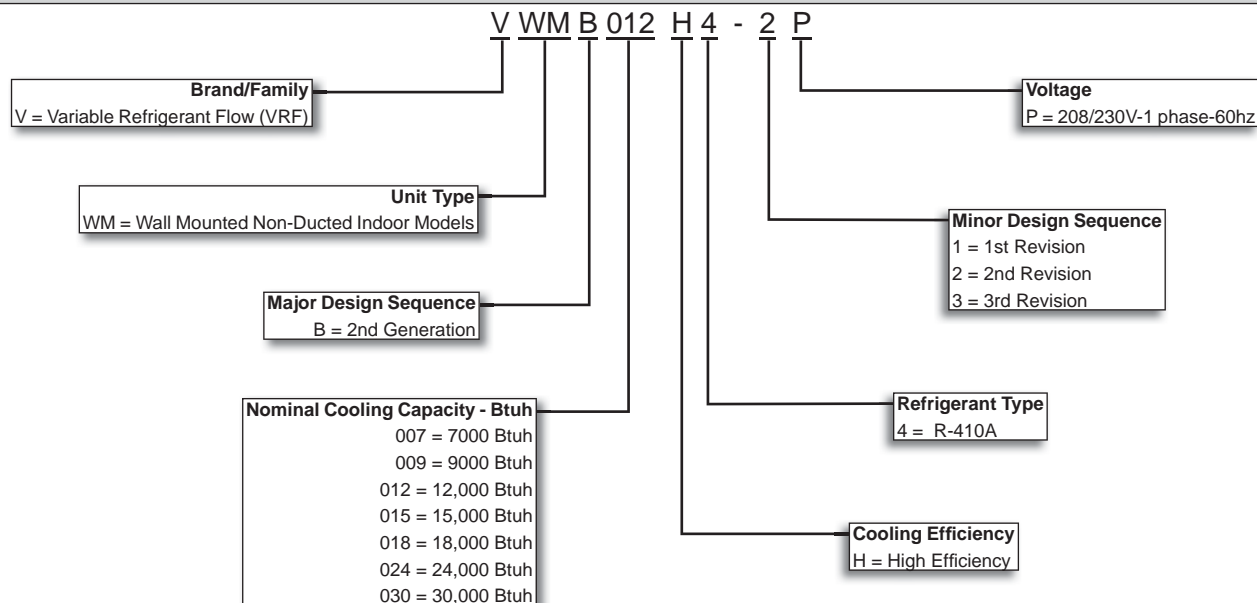

**NOTE** - Only Lennox VRF indoor units will work with Lennox VRF outdoor units and associated mechanical equipment. Lennox Mini Split indoor units are similar in appearance but must not be connected to a Lennox VRF refrigerant circuit. Please refer to model numbers to confirm compatibility. Model numbers for Lennox VRF units start with a "V" and model numbers for Lennox Mini-Splits start with a "M".

## System Piping

### ⚠ CAUTION

VRF system piping is customized for each installation. The LVSS piping report is an engineered design that must be followed. The piping diagram or diagrams included within the LVSS report have been prepared based on the information provided to the Lennox VRF applications department.

When the indicated lengths change from the figures stated within the report, it is imperative that prior to the commencement of the refrigerant pipe work installation, Lennox VRF applications department are informed of these proposed changes.

Upon receipt of this new information the Lennox VRF applications department will confirm any changes that may be applicable to this installation. If changes are required, a new piping diagram will be produced and will supersede all other previously provided documents.

Failure to provide this information regarding changes to the original design may lead to insufficient capacity, equipment failure, warranty being made void and the refusal to commission the system.

**Unit Dimensions - inches (mm)**

**VWMB007H4, VWMB009H4, VWMB012H4, VWMB015H4, VWMB018H4**

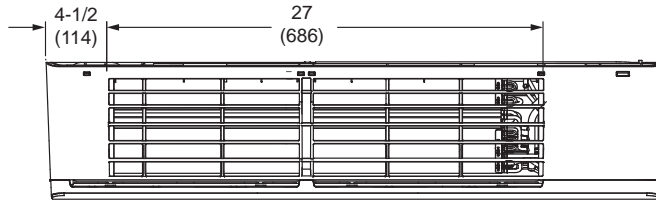

**TOP VIEW**

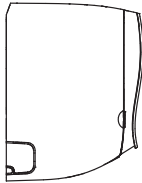

**SIDE VIEW**

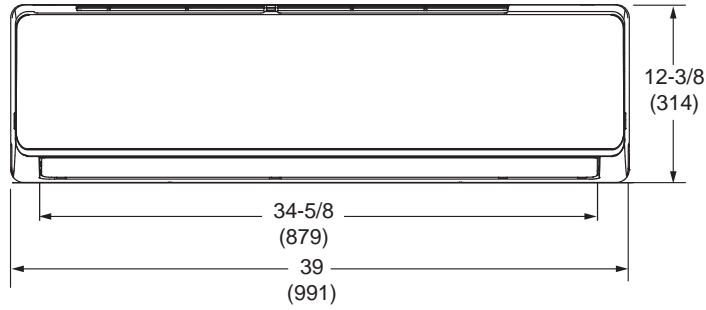

**FRONT VIEW**

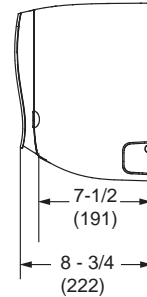

**SIDE VIEW**

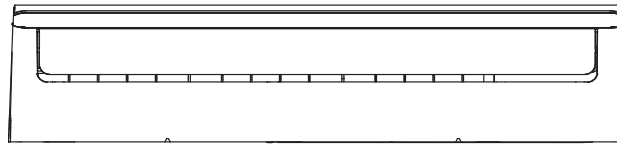

**BOTTOM VIEW**

**VWMB024H4, VWMB030H4**

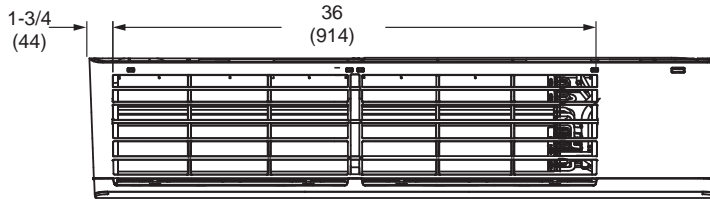

**TOP VIEW**

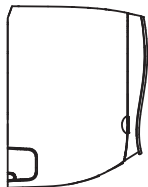

**SIDE VIEW**

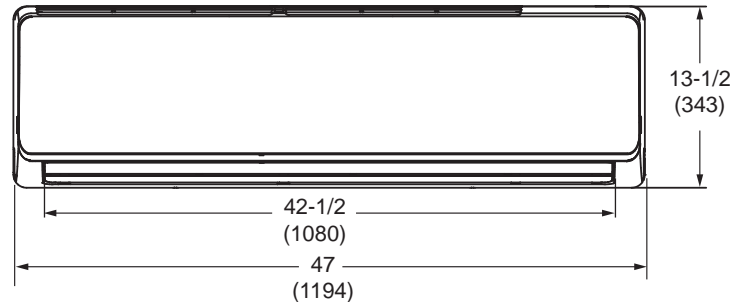

**FRONT VIEW**

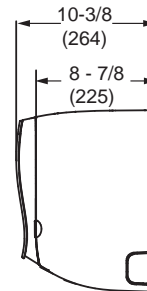

**SIDE VIEW**

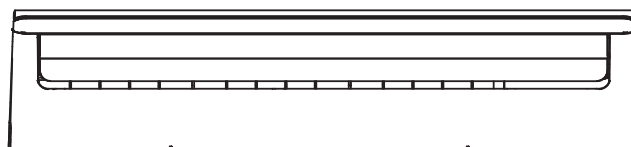

**BOTTOM VIEW**

## Clearances

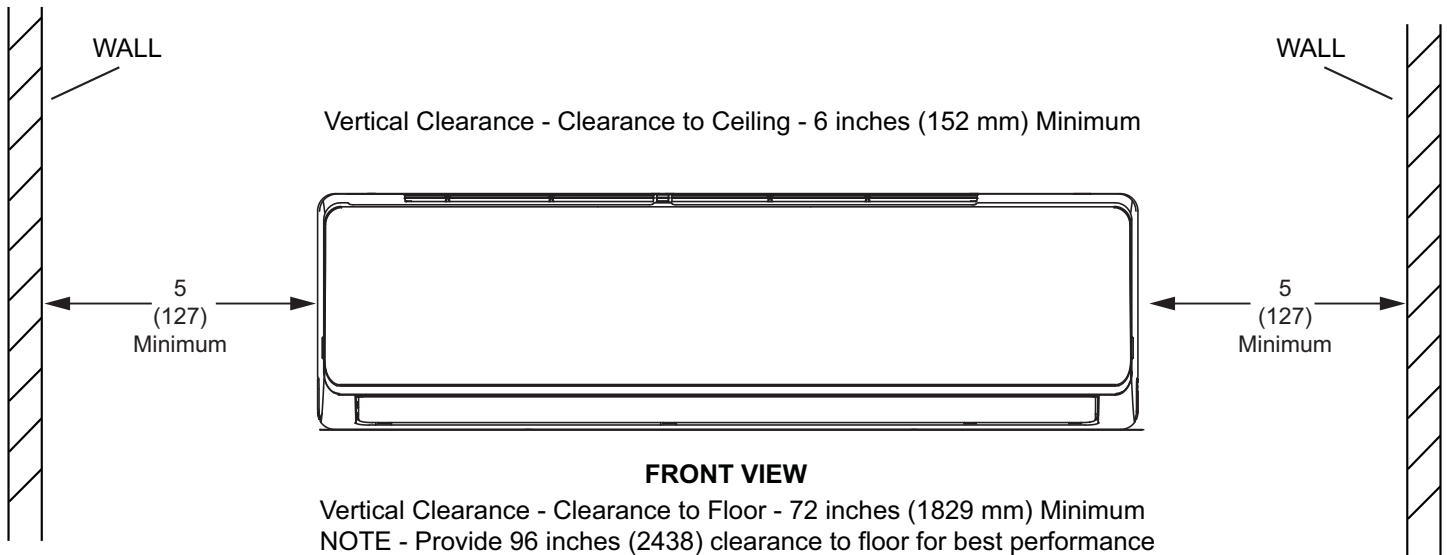

## Indoor Unit Placement

### ⚠ WARNING

Do not install the unit in an area where flammable materials are present due to risk of explosion resulting in serious injury or death.

If the basis underneath the unit is not strong enough to support the weight of the unit, the unit could be fall out of place and cause serious injury.

Use the provided and specified components when installing equipment. Failure to do so may result in unit falling, water leaking or electrical shocks, causing personal injury or equipment or property damage. Check stability of wall-mounted unit support. If support is not capable of carrying weight of the unit, unit may fall causing personal injury or equipment damage.

Consider the possibility of earthquakes in your area when installing the equipment. If the unit is not correctly secured, it may fall, causing personal injury or equipment damage.

Safely dispose of packing materials, which include nails, wood and other sharp objects, as well as plastic wrapping. Children playing with plastic wrap or bags risk the danger of suffocation.

### ⚠ CAUTION

Do not place items which may be damaged by water under or around the indoor unit.

The unit should be installed at least 8 feet above the floor (if possible) to ensure maximum performance and comfort.

### AVOID

Do not install the unit in the following locations:

- Areas exposed to salt or other corrosive materials or caustic gases
- Areas exposed to extreme voltage variations (such as factories)
- Tightly enclosed areas that may impede service of the unit.
- Areas exposed to strong electromagnetic forces
- Areas exposed to acids or alkaline detergents (laundry rooms)

### DO

- Locate the unit so that it is not exposed to direct sunlight.
- Locate the indoor unit so that the room can be uniformly cooled. Install unit as high as possible on the wall (8 feet above floor, if possible) for best performance.
- Select a wall location that can support the weight of the unit.
- Select a location where condensate line will have the shortest run to a suitable drain per local codes.
- Allow sufficient space around unit for proper operation and maintenance (filter must be able to be removed from the top-front of the unit).
- Install the indoor unit a minimum of 3 feet away from any antenna, power cord (line), radio, telephone, security system, or intercom. Electrical interference and radio frequencies from any of these sources may affect operation.

## Determining Wall Mounting Plate Location

1. Remove the wall mounting plate from the back of the indoor unit.

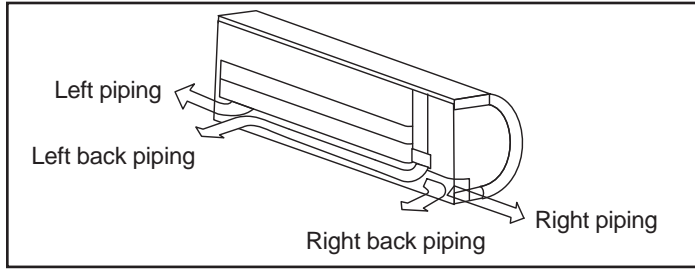

**Figure 1. Determining Exit Locations**

2. Determine the best exit location for utility bundle (line set, condensate line and wiring).
3. Position the wall mounting plate on the wall so that, when installed, the unit will be at least 6 inches (152 mm) from the ceiling and 5 inches (127 mm) from the wall on either side. The wall mounting plate must be level side-to-side.
4. Use the wall mounting plate as a template to determine the exit point for utility bundle. Mark the wall to facilitate drilling hole for utility bundle.

## Installation

### Wall Mounting Plate Installation

Install the wall mounting plate so that it is correctly positioned horizontally and vertically. The indoor unit must be installed level on the wall to allow proper condensate drainage.

1. Use a carpenter's level or measuring tape to verify the wall mounting plate is horizontally level.
2. Secure the wall mounting plate to the wall using the provided screws and screw anchors. NOTE - It is important to use all screws provided to secure the wall mounting plate to the wall. Additional holes may be drilled through the metal wall mounting plate to better secure wall plate. Field-provided anchors/fixings may be required depending on wall construction. Use the appropriate type of anchors for the application.
3. The wall mounting plate must be installed flush against the wall so that the indoor unit will be flush after installation. Any space between the wall and unit will cause noise and vibration.
4. The wall mounting plate must be installed horizontally level on the wall.

### VWMB007H4-2P, VWMB009H4-2P, VWMB012H4-2P, VWMB015H4-2P, VWMB018H4-2P

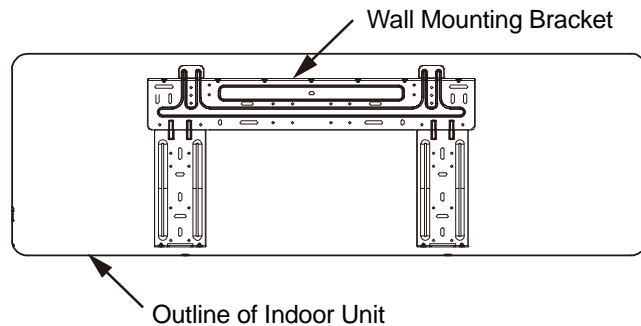

### VWMB024H4-2P, VWMB030H4-2P

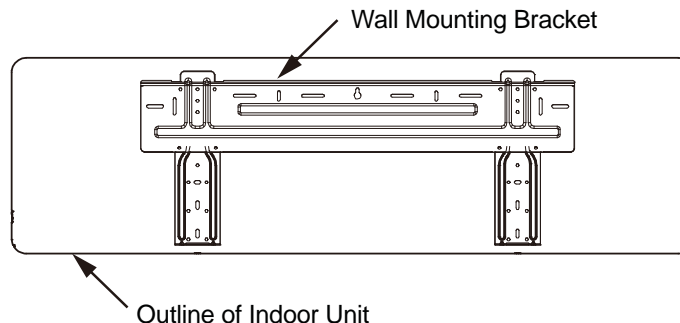

**Figure 2. Wall Mounting Brackets**

## Wall Sleeve Installation

The utility bundle may be routed out of the back of the unit or out either side. If the bundle is to be routed out the back through an external wall, use a field-provided wall sleeve to protect the utility bundle. **NOTE** - If the utility bundle will be routed out the side of the indoor unit and up the wall above a false ceiling, continue to the next section.

1. Prior to making the hole and installing the wall sleeve for the utility bundle, check to ensure that there are no other utilities located in the wall behind the hole location.

### ⚠ WARNING

**Electric Shock Hazard. Can cause injury or death. Avoid location where electric wiring or conduits may be present inside the wall.**

2. Cut a hole in the wall using a suitable hole saw. Hole should be at a slight downward slant - 3/16" to 3/8" toward the outdoor side.

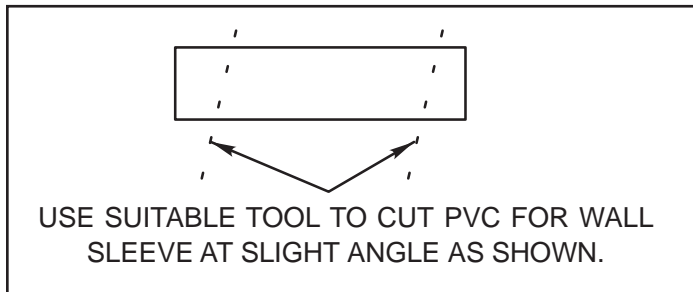

**Figure 3. Boring Hole for Wall Sleeve**

3. Measure the thickness of the wall from the inside edge to the outside edge and cut the field-provided wall sleeve at a slight angle 1/4" (6 mm) shorter than the thickness of the wall.

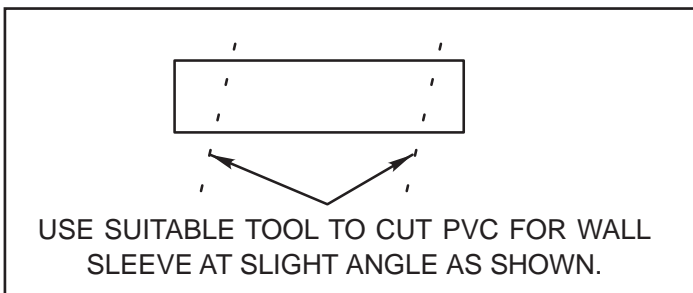

**Figure 4. Cutting PVC for Wall Sleeve**

4. Place the provided plastic cover over the end of the pipe that will be visible from the inside wall and insert the pipe in the wall.

**NOTE** - When passing bundled services through an exterior brick or concrete wall, protect the copper pipes and wiring from the effects of these construction materials by using a sleeve made of a suitable material. The integrity of copper pipe and wiring can deteriorate when exposed to these construction materials

## Install Unit on Wall Mounting Plate

1. A length of field-provided flexible condensate piping should be connected to the drain prior to securing the unit to the wall mounting plate.
2. If the factory-provided refrigerant piping connections and field-provided flexible condensate piping are long enough to enable final field connections after unit is installed on wall mounting plate, use field-provided tape to bundle them together.
3. The utility bundle may be routed out of the back of the unit or out either side. If the bundle is to be routed out the back through an external wall, feed the utility bundle through the wall sleeve. If the utility bundle is to be routed out of the side of the indoor unit and up an inside wall, carefully form the utility bundle so that it makes a gentle 90° turn.
4. Align the back of the indoor unit with the hooks at the top of the wall mounting plate. Move the unit from side to side to make sure that it settles securely.
5. The bottom of the unit can be lifted to facilitate refrigerant piping and condensate drain connections, if necessary. See figure 6.

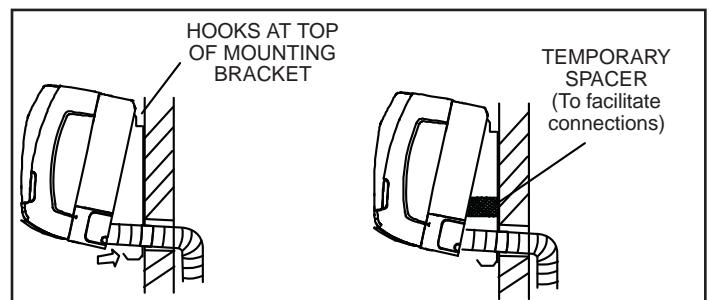

**Figure 6. Secure Unit to Wall Mounting Plate**

## Refrigerant Piping Connections

### ⚠ WARNING

Refrigerant leaks are unlikely; however, if a refrigerant leak occurs, open a door or windows to dilute the refrigerant in the room. Turn off the unit and all other appliances that may cause a spark. Call a licensed professional HVAC technician (or equivalent) to repair the leak.

Use only R410A refrigerant to charge this system. Use of other refrigerant or gas will damage the equipment.

Do not allow air or other contaminants to enter system during installation of refrigerant piping. Contaminants will result in lower system capacity and abnormally high operating pressures and may result in system failure or explosion.

Insulate all refrigerant piping.

Refrigerant pipes may be very hot during unit operation. Do not allow contact between wiring and bare copper pipes.

After refrigerant piping connections have been completed, check the system for leaks per commissioning instructions.

Field piping consists of two copper lines connected to the indoor unit. Table 1 lists the connection sizes at the indoor unit. The connections are made using the provided brass flare nuts at the end of the refrigerant piping connections.

**Both lines must be individually insulated.**

1. The seal on the unit refrigerant piping connections should remain in place until the last possible moment. This will prevent dust or water from getting into the refrigerant piping before it is connected.
2. CAREFULLY adjust refrigerant piping connections to suit the application (straight back, right or left).
3. Slowly loosen one of the flare nuts to release the factory nitrogen charge.
4. Remove the flare nuts from the connections on the unit and discard the seal from each of the piping connections.
5. Slide the flare nuts onto the ends of the field-provided refrigerant piping **before** using a suitable flaring tool to flare the end of the copper pipe.
6. Apply recommended HFC-410A refrigerant lubricant to the outside of the flared refrigerant lines (figure 7-A).

### IMPORTANT!

The compressor in this unit contains PVE oil (Polyvinylether). PVE oil is formulated for hydrofluorocarbon (HFC) refrigerants, such as R-410a, which this system contains. While it may have some miscibility properties with mineral-based oil and POE oil (Polyolester), it is not recommended to mix PVE oil with any other type of refrigerant oil.

Table 1. Refrigerant Piping Connections

Size (Btuh)	Liquid Line in.	Vapor Line in.
7000 9000 12000 15000	1/4	1/2
18000 24000 30000	3/8	5/8

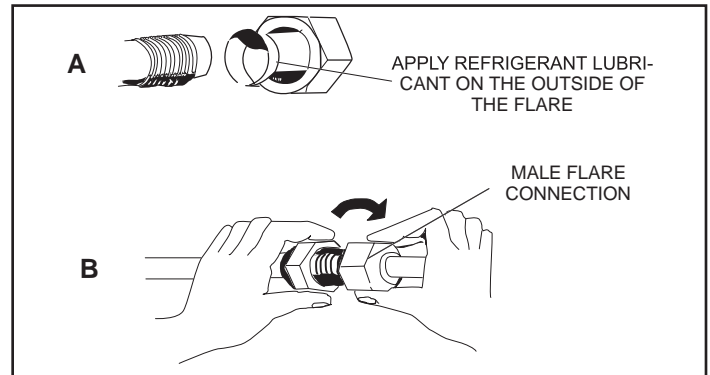

Figure 7. Making Connections (Male to Female Connection)

7. Align the threaded connections with the flared refrigerant lines. Tighten the flare nuts lightly at first to obtain a smooth match (figure 7-B).
8. Once snug, continue another half-turn on each nut which should create a leak-free joint. A torque wrench may be used to tighten flare nuts using table 2 recommendations. See figure 4. **Do not over-tighten a flared joint. Flared connections should always be accessible and must be insulated to prevent condensation.**
9. After refrigerant piping has been installed and checked for leaks, apply insulation over the connector pipe and all flared connections.

### IMPORTANT!

**Always use two wrenches when tightening flare nuts to avoid twisting refrigerant piping. DO NOT over-tighten flare nuts.**

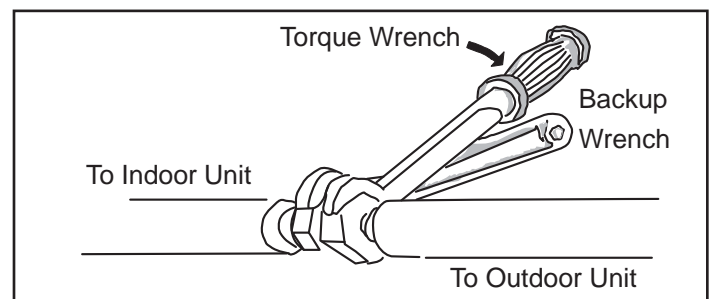
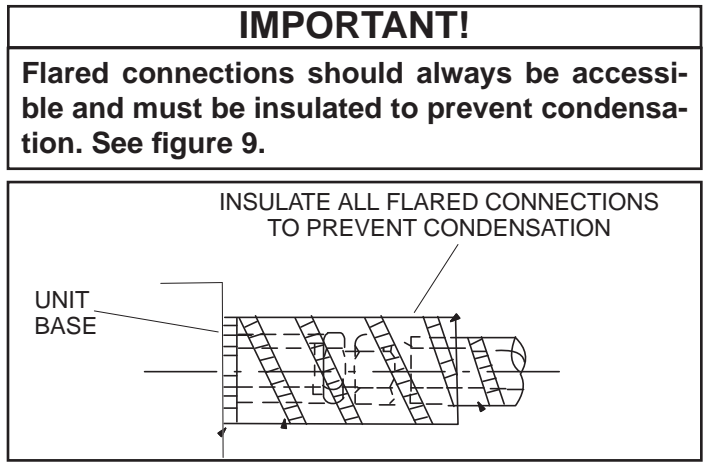

Figure 8. Tighten Flare Nut

**Table 2. Flare Nut Torque Recommendations**

Outside Diameter	Recommended Torque	No torque wrench available Finger tighten and use an appropriately sized wrench to turn an additional:
Inches	U.S.	
1/4"	15 ft.-lb.	1/4 turn
3/8"	26 ft.-lb.	1/2 turn
1/2"	41 ft.-lb.	7/8 turn
5/8"	48 ft.-lb.	1 full turn



**Figure 9. Insulate Flared Connections**

**Condensate Piping Connections**

**▲ CAUTION**

**Make sure that drain piping is properly routed and insulated in order to prevent both leaks and condensation.**

1. Make a water-tight connection between the field-provided condensate drain line and the flexible condensate connector (5/8" I.D.).
2. See figure 10 for applications including a single unit and a single drain. In this case, ensure that the drain line is properly sloped (no less than 1/4 inch per foot) and condensate lines are routed to ensure moisture is drained away from the indoor unit.
3. Drain should be as short as possible and should not have any droops or kinks that would restrict condensate flow and shall be approved resistant pipe. **There must be a 2-inch space between the end of the condensate drain and the final termination point (ground, open drain, etc.) to ensure that the line will drain freely.**
4. After system installation is complete, the condensate drain line must be checked for leaks. This check is part of the commissioning sequence. If a field-provided condensate pump has been installed, it must be checked to ensure proper operation. This check is part of the commissioning sequence.

**IMPORTANT!**

**Drain should have a slope of at least 1/4 inch per foot and should be approved corrosion-resistant pipe. You must confirm operation of every drain and pump in the system as part of the commissioning procedure.**

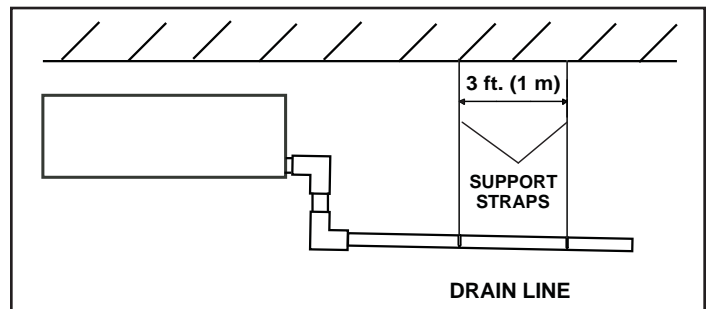

**Figure 10. Condensate Drain Piping**

**Using an External Water Level Switch**

Disconnect the closed circuit loop, CN 19. Connect the water level switch cable accessory to CN 19. See unit wiring diagrams for location of CN 19.

The connection has 5 VDC current, do not supply field voltage.



**Table 3. Condensate Pump Accessory Options**

Capacity	Brand	Model Name	Model #	Cat #	Max Flow Rate (gal per hr)	Max head (ft.)	Max suction lift*
VWMB007H4-2 - VWMB018H4-2	Blue Diamond	MicroBlue	X85-003	14T74	1.3	16	6 ft
VWMB007H4-2 - VWMB018H4-2		MicroBlue Fascia Kit	T18-016	17A24	-	-	-
VWMB024H4-2 - VWMB030H4-2		MaxiBlue w Reservoir	X87-721	14T69	3.7	23	16.5 ft
VWMB024H4-2 - VWMB030H4-2		MaxiBlue w DrainStik	X87-722	17A23	3.7	23	16.5 ft

\*Optional pump maximum suction lift is measured from the pump outlet.

**Wiring Connections**

**⚠ WARNING**  
 Isolate the power supply before accessing unit electrical terminals.  
 Install unit so that unit disconnect is accessible.  
 Follow all local and national codes, as well as this installation instruction, during installation. Do NOT overload electrical circuit, as this may lead to failure and possible fire.  
 Use specified wiring and cable to make electrical connections. Clamp cables securely and make sure that connections are tight to avoid strain on wiring. Insecure wiring connections may result in equipment failure and risk of fire.  
 Wiring must be installed so that all cover plates can be securely closed.

**⚠ CAUTION**  
 This unit must be properly grounded and protected by a circuit breaker. The ground wire for the unit must not be connected to a gas or water pipe, a lightning conductor or a telephone ground wire.  
 Do not connect power wires to the outdoor unit until all other wiring and piping connections have been completed.  
 Install all wiring at least 3 feet away from televisions, radios or other electronic devices in order to avoid the possibility of interference with the unit operation.  
 Do not install the unit near a lighting appliance that includes a ballast. The ballast may affect remote control operation.

1. Lift indoor unit front panel to access the control box over. Remove the screw(s) securing the cover. Remove the plate.
2. Locate the terminal strip in the control box. Connect the power wiring (sized per NEC/CEC and local codes) and communications cable (**three-conductor, shielded cable**). Refer to unit nameplate for rated voltage.
3. If the indoor unit is the final unit in a group that is wired in series, install the provided resistor across terminals P and Q.
4. Remove spacer. Secure bottom of unit to wall mounting bracket. Continue with installation of outdoor unit and system commissioning.

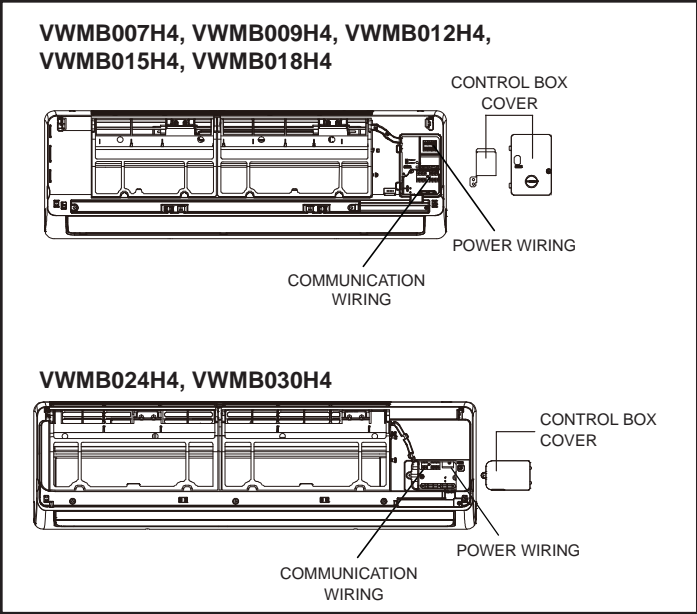

**Figure 11. Accessing Control Box**

In the U.S.A., wiring must conform with current local codes and the current National Electric Code (NEC). In Canada, wiring must conform with current local codes and the current Canadian Electrical Code (CEC).

Refer to unit nameplate for minimum circuit ampacity and maximum overcurrent protection size.

**NOTE** - Three-conductor shielded cable must be used for the communication wiring. This is necessary to ensure proper system communication and operation.

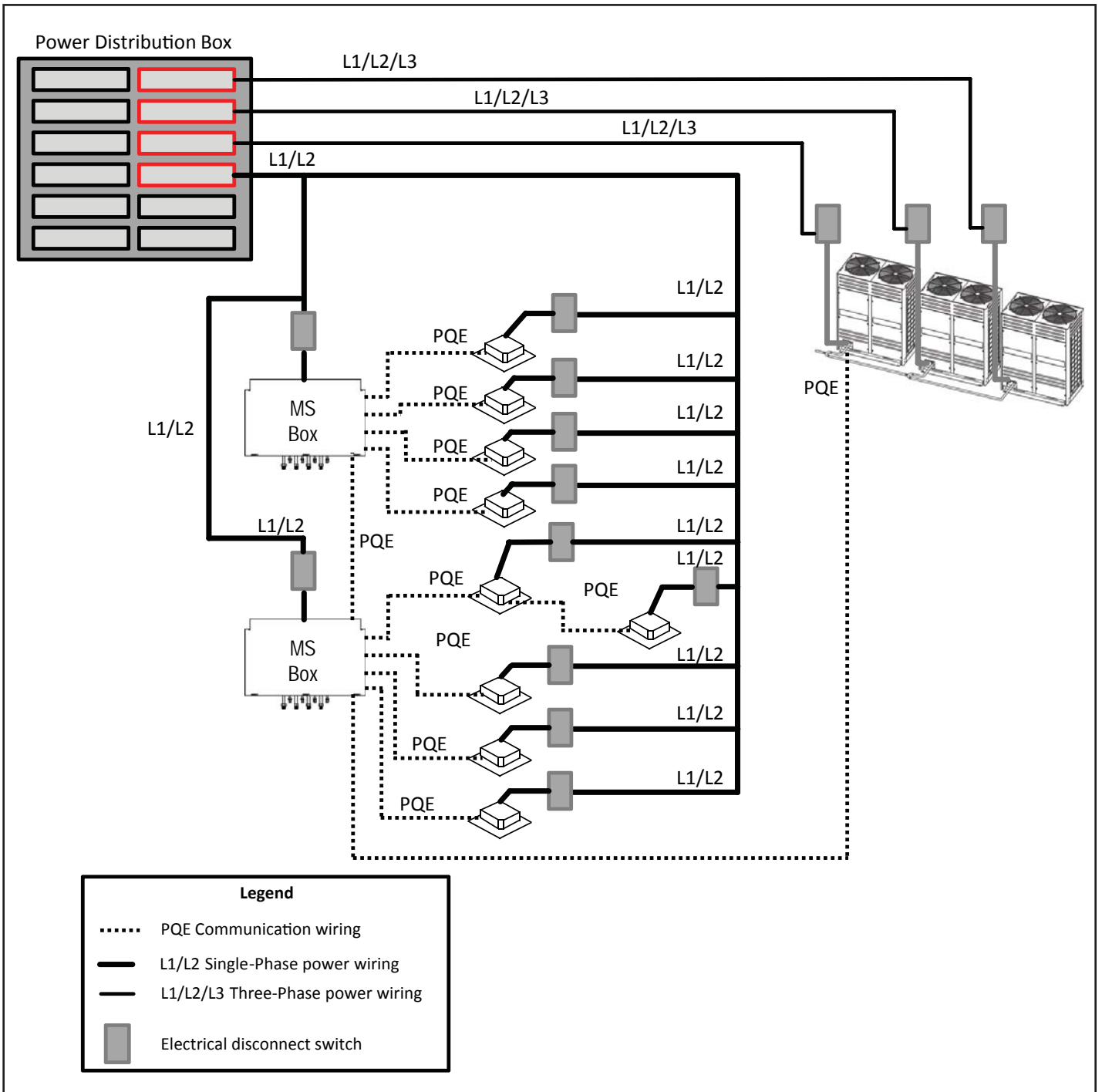

Figure 12. Typical Power Wiring Diagram (VRF Heat Recovery System Shown)

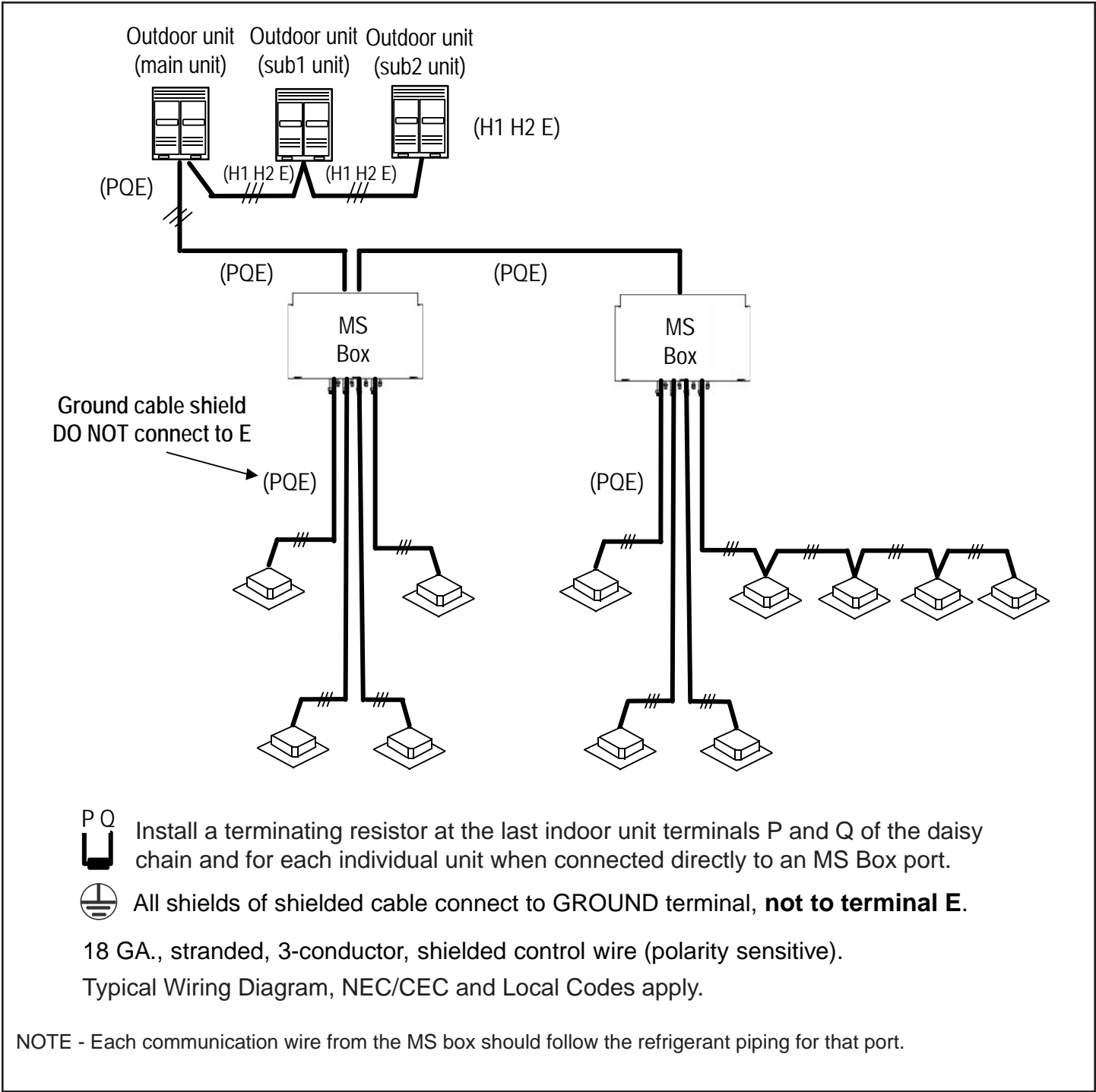
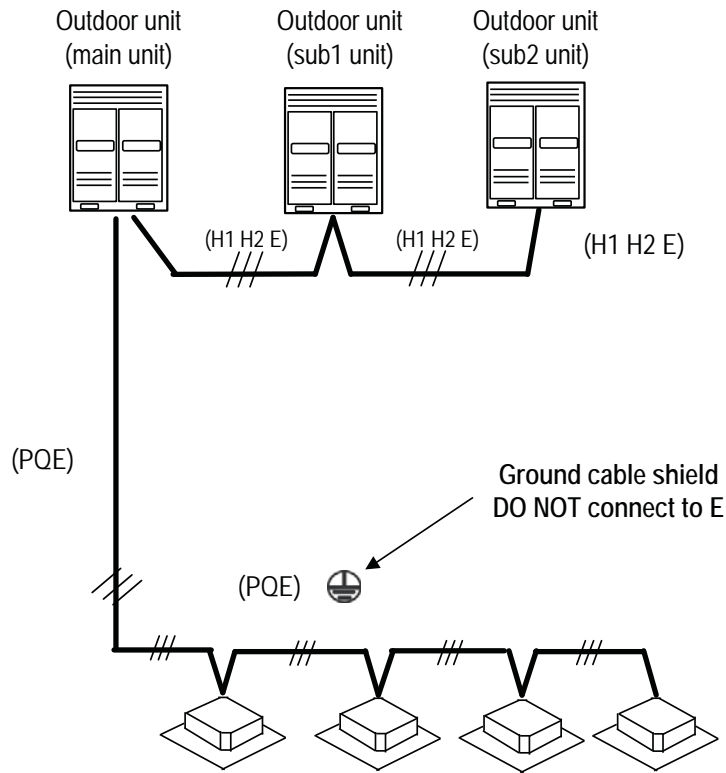



Figure 13. Typical Communication Wiring Diagram (VRF Heat Recovery System)



 Install a terminating resistor at the last indoor unit terminals P and Q of the daisy chain.

 All shields of shielded cable connect to GROUND terminal, **not to terminal E**.

18 GA., stranded, 3-conductor, shielded control wire (polarity sensitive).

Typical Wiring Diagram, NEC/CEC and Local Codes apply.

**NOTE** – PQE Communication wiring is daisy-chained from the outdoor unit to each indoor unit in one continuous run.

**Figure 14. Typical Communication Wiring Diagram (VRF Heat Pump System)**

Code	Name
FM	Indoor fan motor
GM	Swing motor
PMV	Electronic expansion valve
T1	Room temp. sensor
T2	Mid-pipe temp. sensor
T2B	Outlet pipe temp. sensor
XP1-5/XS1-5	Connectors
XT1/XT2	Terminal

**NOTE:**  
COMPONENT IN DASH LINE IS  
OPTIONAL OR FIELD WIRING

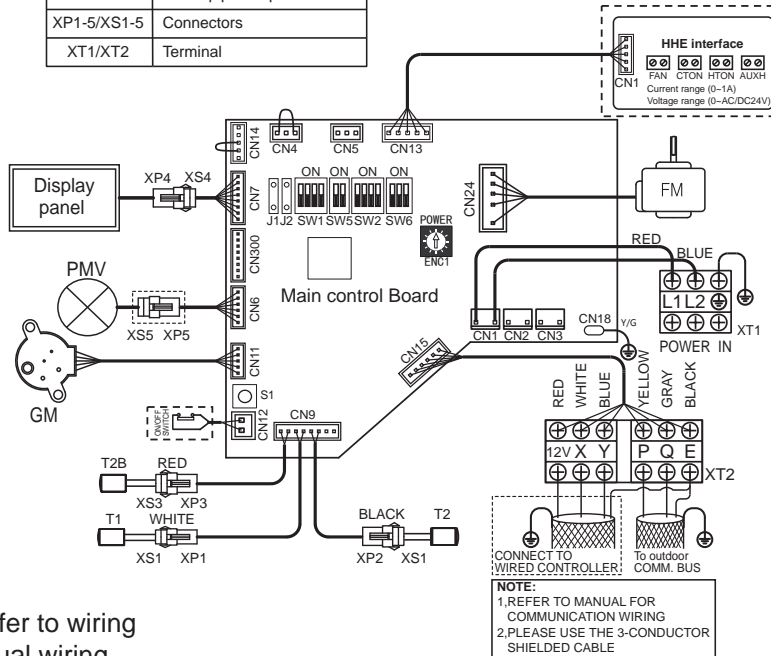

Typical wiring diagram. Refer to wiring diagram on the unit for actual wiring.

**Figure 15. Typical VWMB007H4-2 to VWMB018H4-2 Wiring Diagram**

Code	Name
FM	Indoor fan motor
GM	Swing motor
PMV	Electronic expansion valve
T1	Room temp. sensor
T2	Mid-pipe temp. sensor
T2B	Outlet pipe temp. sensor
XP1-5/XS1-5	Connectors
XT1/XT2	Terminal

**NOTE:**  
COMPONENT IN DASH LINE IS  
OPTIONAL OR FIELD WIRING

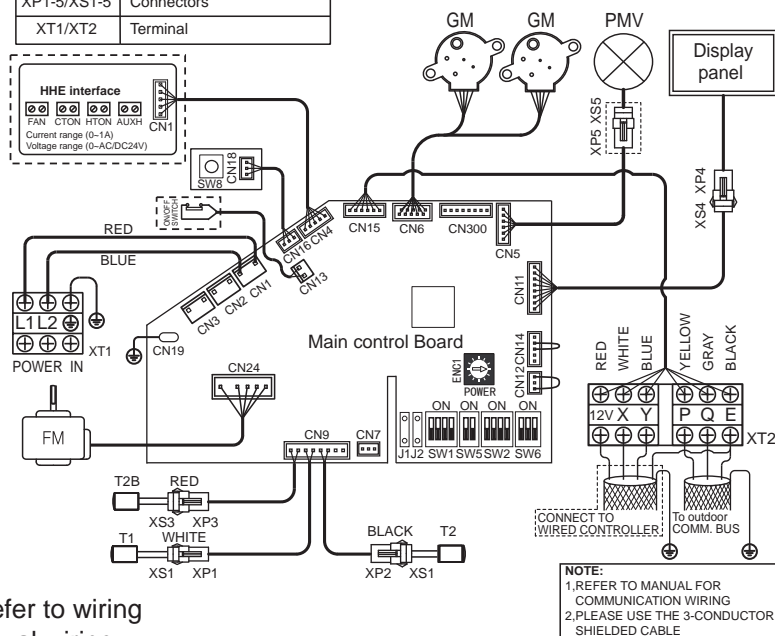

Typical wiring diagram. Refer to wiring diagram on the unit for actual wiring.

**Figure 16. Typical VWMB024H4-2 to VWMB030H4-2 Wiring Diagram**

## Auxiliary Heat Relay

Cat #	Model #	Description
13G98	V0CTRL92P-1	VRF HHE Relay Kit

## Network Address and Commissioning

After the system has been installed, each indoor unit must be assigned an address as part of the commissioning procedure.

**NOTE** - The indoor unit temperature unit display must be set at the same time as the controller. Indoor units default to display temperatures in °F. VWM\*024 and larger: To change the indoor unit temperature unit display, press and hold the SW3 button on the unit main control board for 5 to 15 seconds until the display changes to show the desired temperature unit.

## Technical Support

1-844-GET-VRF1

(1-844-438-8731)

vrftechsupport@lennoxind.com

www.LennoxVRF.com

Download the app  
from the Apple App Store or the Google Play store.

