



SUBMITTAL DATA – INDOOR UNIT VHIA072S4-2P

VRF HEAT PUMP & HEAT RECOVERY

Job: _____

Location: _____

Schedule No.: _____

System Designation: _____

Engineer: _____

Architect: _____

Date: _____

For: Reference Approval Review Construction

High Static Ducted Indoor Unit

FEATURES

- Pre Heat Function
- Auto Addressing
- Auto Restart
- Optional Condensate Pump
- Electronic Expansion Valve
- Factory Secondary Drain Pan
- Flare Connections
- LED Display
- Refrigerant R-410A
- Seven capacity sizes from 24,000 to 96,000 Btu/h

SPECIFICATIONS

PERFORMANCE

Cooling Capacity ¹ (Btu/h)		72,000
Heating Capacity ¹ (Btu/h)		80,000
Airflow (CFM)	High	2,814
	Medium	2,660
	Low	2,235
External Static Pressure (in. WC)		0.20 - 1.13
Sound Pressure (dBA)	High	59
	Medium	55
	Low	52

ELECTRICAL DATA

Power Supply (V/Hz/Φ)	208-230/60/1
Minimum circuit ampacity (MCA)	7.5
Max. Overcurrent Protection (MOCP)	15
Cooling Power Input ² (W)	1490
Cooling Rated current (A)	6.5
Heating Power Input ² (W)	1490
Heating Rated current (A)	6.5
Indoor Fan Motor Input (W)	(2) 745

DIMENSIONS

Unit Dimensions (in)	Height	18-1/2
	Width	56-5/8
	Depth	33-1/8
Liquid Pipe Connection (in)		(2) 3/8
Gas Pipe Connection (in)		(2) 5/8
Condensate drain connection (in)		(1) 1-1/4
Unit Shipping Weight (lb)		284
Unit Net Weight (lb)		218



OPTIONAL ACCESSORIES

<input type="checkbox"/> Non-Programmable Controller	V0STAT54P
<input type="checkbox"/> Programmable Controller	V0STAT51P
<input type="checkbox"/> Infrared Wireless Controller	V0STAT52P-1
<input type="checkbox"/> Infrared Sensor	V0SNSR78P-1
<input type="checkbox"/> Remote Sensor	V0SNSR00P-1
<input type="checkbox"/> HHE Relay Kit	V0CTRL92P-1
<input type="checkbox"/> Hotel Keycard Interface	V0CTRL88P-1
<input type="checkbox"/> Drain Pump Kit	V8DRNP04

NOTES

1. Cooling and Heating capacity data is rated at the following conditions:
Cooling: 80°FDB / 67°FWB Indoor, 95°FDB Outdoor
Heating: 70°FDB Indoor, 47°FDB / 43°FWB Outdoor
2. Power Input values are rated at high fan speed.



NOTE – Due to Lennox' ongoing commitment to quality, Specifications, Ratings and Dimensions subject to change without notice and without incurring liability. Improper installation, adjustment, alteration, service or maintenance can cause property damage or personal injury. Installation and service must be performed by a qualified installer and servicing agency.



SUBMITTAL DATA – INDOOR UNIT

VHIA072S4-2P

VRF HEAT PUMP & HEAT RECOVERY

DIMENSIONAL DRAWINGS - INCHES (MM)

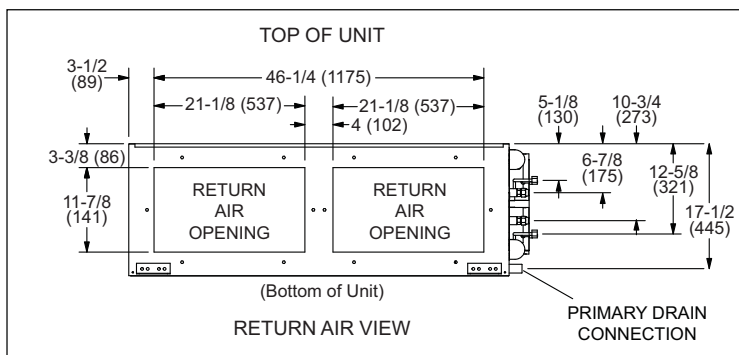
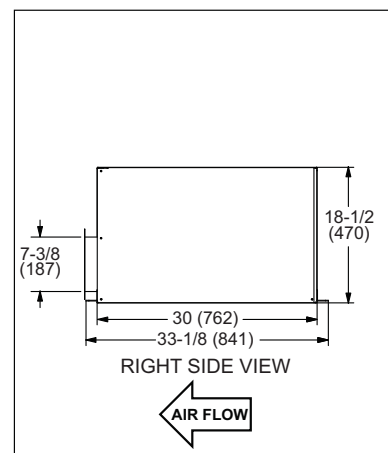
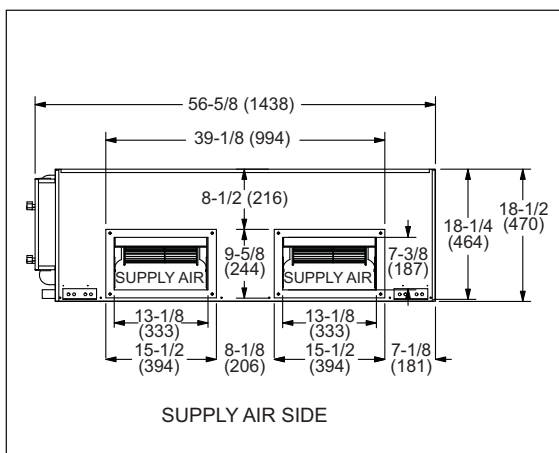
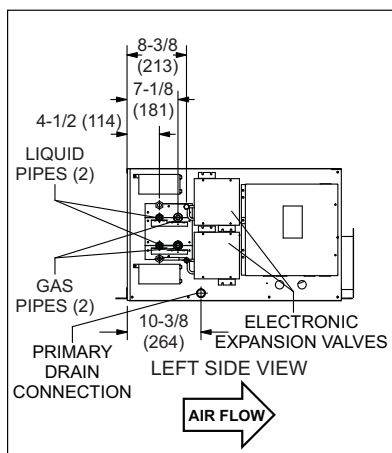
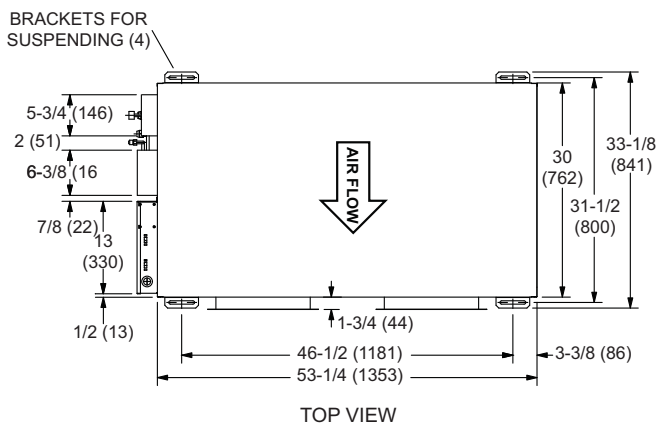

NOTE – Due to Lennox' ongoing commitment to quality, Specifications, Ratings and Dimensions subject to change without notice and without incurring liability. Improper installation, adjustment, alteration, service or maintenance can cause property damage or personal injury. Installation and service must be performed by a qualified installer and servicing agency.

495356 (201804)

©2018 Lennox Industries Inc.